

# DEVELOPMENT OF A COMPUTER CODE TO MINIMIZE OCCUPATIONAL DOSES DURING DECOMMISSIONING OR RADIOACTIVE WASTE HANDLING OPERATIONS

J.R. Costes

Commissariat à l'Energie Atomique, Decommissioning Department  
B.P. 171, 30205 Bagnols-sur-Cèze, France

O. Chuzel and M. Bergman  
Institut Systemia,  
Aix-en-Provence, France

## ABSTRACT

Despite continuing progress in reducing the occupational radiation doses incurred as a result of decommissioning nuclear facilities or nuclear waste management activities, it is difficult to provide satisfactory answers to two simple questions: *Can the occupational dose be predicted within 10%?* and *Is this the lowest reasonably achievable dose?*

This paper addresses both questions. The use of a gamma camera is recommended to provide positive identification of all radioactive sources. The source data can then be used by a calculation model to define the minimum occupational dose by optimizing the decommissioning task sequence.

## INTRODUCTION

### Minimizing Occupational Doses

The objective of maintaining occupational doses "as low as reasonably achievable", the increasing volume of maintenance and decommissioning work, and the changing regulatory context have incited operators and contractors to develop means of predicting and analyzing dosimetry results in order to minimize their incidence. Occupational doses may be reduced in four ways: by improving the design of nuclear facilities to optimize their operation, maintenance and decommissioning; by directly modifying the radiation sources through decontamination and biological shielding; by improving maintenance procedures, equipment and personnel training; and by improving dose prediction and management techniques.

We are concerned here only with the last point. Our objective is to develop a model to minimize occupational doses during manual decommissioning or nuclear waste handling operations. The ultimate goal is to determine the optimum task sequence so that operators have received the lowest reasonably achievable radiation dose on completion of the work.

### The State of the Art

Despite continuing developments in this area, in the ever-changing environment of a decommissioning operation it is still problematic for a site manager to answer two simple questions: *Can the occupational dose for a specific decommissioning task be predicted within 10%?* and *Is this the lowest reasonably achievable dose?* Nevertheless, computer-aided techniques have made some progress in recent years.

Electricité de France (EDF), the French national electrical utility, has developed an analytical dosimetry program, DOSIANA (1), to monitor and protect its employees involved in repetitive tasks. Real-time dose rate statistics are compiled for each work site, allowing analysis of the performance achieved to predict and improve the results for similar tasks at other sites.

A European research contract was granted to the German firm NIS (2) to investigate methods and data bases for

estimating the cost and dose rates sustained during decommissioning activities, based on analysis of standard data collection forms for a wide variety of projects. This method should provide general orders of magnitude, but is unlikely to be applicable to specific projects.

A more promising approach has been undertaken in Italy by Energia Nucleare e Energie Alternative (ENEA) under a program known as SMANT (3) to optimize the decommissioning sequence for a nuclear facility in order to limit the occupational dose. The installation is subdivided into rectangular prisms called *rooms*, which may or may not contain one or more components. The components themselves are described with reasonable precision. Nevertheless, the method of determining the dismantling sequence does not necessarily provide the lowest possible dose rate (the procedure begins by removing the most highly radioactive component).

The two fundamental questions may be answered by systematic use of a gamma camera to obtain reliable radioactivity maps, and by software analysis of these results to determine the optimum decommissioning task sequence.

### THE GAMMA VIDEO CAMERA

A video camera with a highly sensitive CCD array is used to display gamma-emitting radiation sources superimposed on a visible light image. The gamma camera is a compact device, 150 mm in diameter and 350 mm long, that can easily be used to scan the interior of shielded cells via standard telemanipulator or waste removal ports. Its real-time detection capability allows satisfactory measurement rates (less than 10 minutes) when multiple sources are present.

The device basically comprises the following:

- a double-cone pinhole collimator made of highly absorbent material, with a thin shutter that opens only for the visible light exposure time;
- a detector consisting of a scintillation screen transparent to visible light, which converts gamma photons into visible light for the CCD;
- signal processing circuitry both in the video camera (two high-efficiency light intensifiers and a highly

sensitive CCD array supplying a standard 625line 50 Hz CCIR video signal) and in a remote unit several meters away (signal acquisition, integration, processing, superposition and output for display on a video monitor).

The same technique has also been implemented in a still camera using a photographic emulsion, although this solution is slower and less sensitive than the video camera. Both cameras provide a comprehensive view of the radioactive environment in which operators will be required to work. A future development will allow stereoscopic imaging to eliminate some remaining ambiguities.

The system provides a black-&-white visible-light image on which radiation sources are superimposed in color-coded form to indicate dose rate levels in  $10^{-2}$  mGy·h<sup>-1</sup> at 1 meter.

Before initiating any decommissioning operation, a complete panoramic display of the site is obtained through all available ports. This radiation mapping phase is the key to successful optimization of occupational doses.

### MINODDIN: SOFTWARE TO MINIMIZE OCCUPATIONAL DOSES DURING DECOMMISSIONING OF NUCLEAR FACILITIES

In a zone encumbered with equipment and containing several radioactive sources of different intensities, it is reasonable to assume that the order in which the radioactive items are dismantled is a significant factor: *the final occupational dose will vary according to the sequence of operations*. The optimum sequence is not intuitively obvious, and can only be determined by computer-aided means. This involves defining the work area in simple geometric terms, defining the duration of personnel exposure, and minimizing the doses by selecting the best set of options for a given context.

#### Description of the Decommissioning Zone

There is often some degree of uncertainty on the dose rate distributions and the positions of sources and obstacles. In order to allow for this uncertainty, we chose to represent the objects and dose rates in the form of a *quadtree*, which provides a 2dimensional spatial representation. Each node of this tree structure has 4 branches, hence the name *quadtree*; the depth of the branches indicates the level of the itemized breakdown. The leaves represent individual cells corresponding to the best known areas.

The quadtree technique is widely used for image analysis. A given space may be divided into four equal regions, each of which may be further subdivided into four regions; the process may be repeated as often as necessary. Each cell is numbered in base 4 according to an N-shaped pattern beginning with 0 in the lower left corner (Fig. 1).

The base 4 numbering technique allows easy identification of adjacent cells; it limits the number of digits required to designate a specific cell, and thus helps to minimize the computer time. The same technique can be generalized to an *octree* (base 8) describing three-dimensional space.

In the Minoddin code, the most detailed representation corresponds to two levels of  $16 \times 16$  rectangular cells of known dimensions. The second level is provided to account for nuclear cells containing mezzanines or high-placed objects accessible from platforms, balconies or ladders. The operator may designate up to six routes between the first and second levels; only a single exit is provided from the first level.

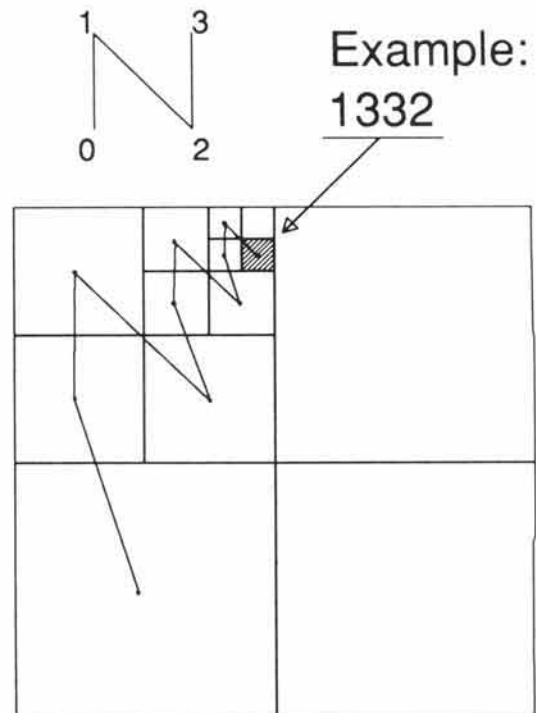

Fig. 1. QUAD TREE N-shaped pattern.

#### Calculating the Dose Rate at Any Point and the Absorbed Dose

The dose  $D$  absorbed by an operator is determined from the following relation:

$$D = d \cdot t \cdot k$$

where

$D$  : absorbed dose ( $10^{-2}$  mSv)

$d$  : ambient dose rate ( $10^{-2}$  mSv·h<sup>-1</sup>)

$t$  : exposure time (hours)

$k$  : adjustment or weighting coefficient

Radiation sources are characterized by their position  $(x,y)$ , the necessary working time ( $t_w$ ), their type (point or extended) and their dose rate at 1 meter ( $d_0$ ). The dose rate attributable to a source  $S$  at a given point  $(x,y,z)$  is expressed as follows:

$$d_{s(x,y,z)} = \frac{d_0}{r_s^2} \quad \text{if } S \text{ is a point source}$$

$$d_{s(x,y,z)} = \frac{d_0}{r_s} \quad \text{if } S \text{ is an extended source}$$

where  $r_s$  is the distance between source  $S$  and point  $(x,y,z)$ .

The dose rate of all the sources  $S$  at a point  $S_m$ , which is also a source, is expressed by the following relation:

$$d_{s_m} = d_{o_{s_m}} + \sum d_s \quad \text{A dose rate is thus assigned to each cell.}$$

The exposure time is the sum of the unit working times  $t_w$  (i.e. dismantling, waste handling and removal) and the time required by the operator to enter and leave the zone. The absorbed dose for all sources  $S_m$  is then:

$$D_{s_m} = t_{w_m} \cdot C_p \cdot \sum_i^n d_n + t_{w_j} \cdot d_{s_m}$$

where  $d_n$  represents the dose rates in the  $n$  cells on the in/out route, and where the transit time is assumed equal to a fraction  $C_p$  of the working time  $t_{w_m}$  for source  $S_m$ .

Obstacles are handled by the code as cells through which it is impossible to transit. Low-level irradiating objects are considered as sources with a zero dose rate. It may be necessary to remove them before the sources in order to gain access or to save time.

### Dose Minimization Algorithm

Determining an optimum dismantling sequence for  $n$  sources involves  $n$  factorial ( $n!$ ) possible combinations. For each combination, all the minimal paths in the quadtree must be constructed in terms of occupational dose between the sources and the zone access door. No more than one source is dismantled at a time, and it is removed via the access door. The path must be recalculated after each operation, since the dose rate map has been modified.

The algorithm uses an iterative process of minimal dose propagation from the "exit" point  $p$ . An array  $T$  containing  $256 \times 256$  cells is created to enter all the corresponding doses  $T_{ij}$ . A second array  $T^*$  containing  $256 \times 257$  cells is then created to enter all the doses sustained in moving from point  $i$  to point  $p$  via another (unique) point  $j$ .

Table  $T^*$  thus includes two regions separated by the diagonal (Fig. 2). All the values in the upper (right-hand) triangle are expressed as follows:

$$T^*_{ij} = T_{ij} + T_{pj} \quad \text{i.e. the route from point } i \text{ to point } j, \text{ and from point } j \text{ to point } p,$$

except for the initial step:  $T^*_{ip} = T_{ip}$ . The values in the lower (left-hand) triangle may be simplified to:

$$T^*_{ij} = T_{ij} + T_{j,257}$$

provided the entry in the last column,  $T_{i,257}$ , is the minimum  $T^*_{ij}$  value in row  $i$ .

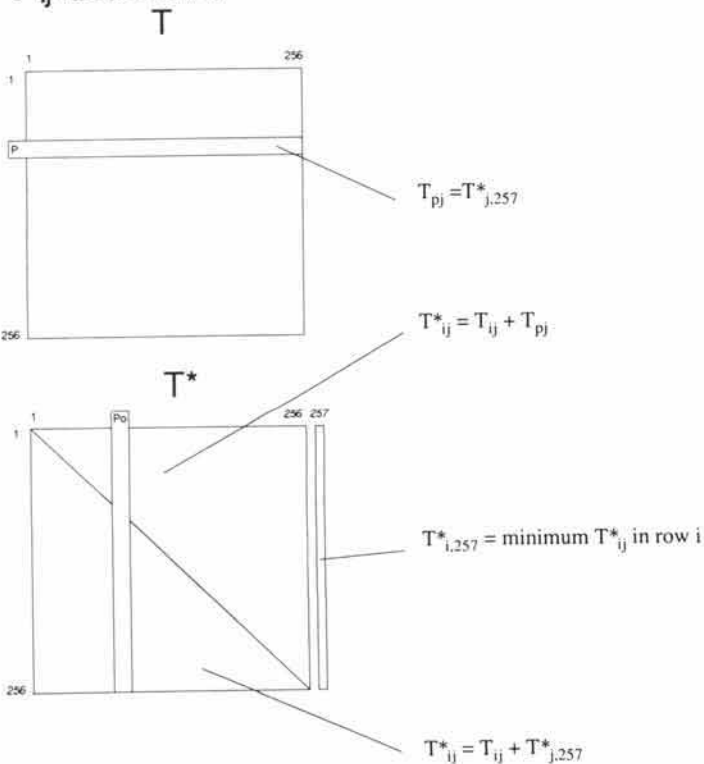

Fig. 2. Arrays  $T$  and  $T^*$  to minimize paths in the quadtree.

Following this initial calculation, the last column contains the minimum dose values of all the routes to point  $p$  via another point. These values may then simply be transferred to row  $p$  of Table  $T$ , as follows:

$$T_{pj} = T^*_{j,257}$$

After the second iteration, column  $T^*_{i,257}$  contains the minimum doses along the route from all points to  $p$  via no more than two other points. The process is repeated in this way until column  $T^*_{i,257}$  does not vary between two iterations. The  $T^*_{i,257}$  values then represent the minimum doses for all the points from  $i$  to  $p$ .

By generalizing this process to a  $532 \times 532$  array, representing two  $16 \times 16$  levels with the routes between them (e.g. stairs), it is possible to calculate the routes along which operators will sustain the lowest doses as they dismantle a source. The process is enhanced by simultaneously following the shortest possible geometric paths.

After examining all  $n!$  source permutations, the results are sorted according to the dose incurred. The code also displays the status of both cell levels after each source is dismantled, together with the recommended in and out routes from the cell exit door.

### Artificial Intelligence Module

Processing  $n!$  permutations is time-consuming on a microcomputer. An artificial intelligence layer is used to limit the number of possible solutions to a maximum of  $7!$  (i.e. 5040) whenever possible.

It is therefore advisable to conduct several consecutive simulations, including preliminary tasks (e.g. setting up biological shielding, prior decontamination) in order to ensure that the final scenario does in fact represent the minimum occupational dose. This requires a specific "preparation" code version.

Some permutations are automatically excluded. These include sources hidden behind other sources, very low-level remote sources, and highly contaminating sources eliminated last. Allowance is also made for certain procedural requirements, such as the maximum exposure time, or the maximum work duration while wearing a mask; these time limits imply additional round trips, working time and irradiation. This approach provides for a more realistic simulation.

The system was developed from a Distributed Artificial Intelligence platform (called RYLM) using the concept of *agents*. This environment is capable of representing project constraints, implementing heuristic calculations, and managing the quadtree and the minimal path-seeking module. The program runs on an i486 microcomputer with extended memory.

### Example

The program has been tested, for example, by simulating the human dismantling operations for a utility room adjacent to cesium source conditioning cells. Several contaminated ventilation ducts crossed through the room at a height of 2.5 meters. Figure 3 shows the two arrays corresponding to the two working levels: floor level and duct level (+2.5 m). Gamma camera measurements identified five sources which are marked in the arrays.

MINODDIN allowed several scenarios (setting up biological shielding or prior decontamination) to be simulated. In the recommended scenario, the ducts were opened and the

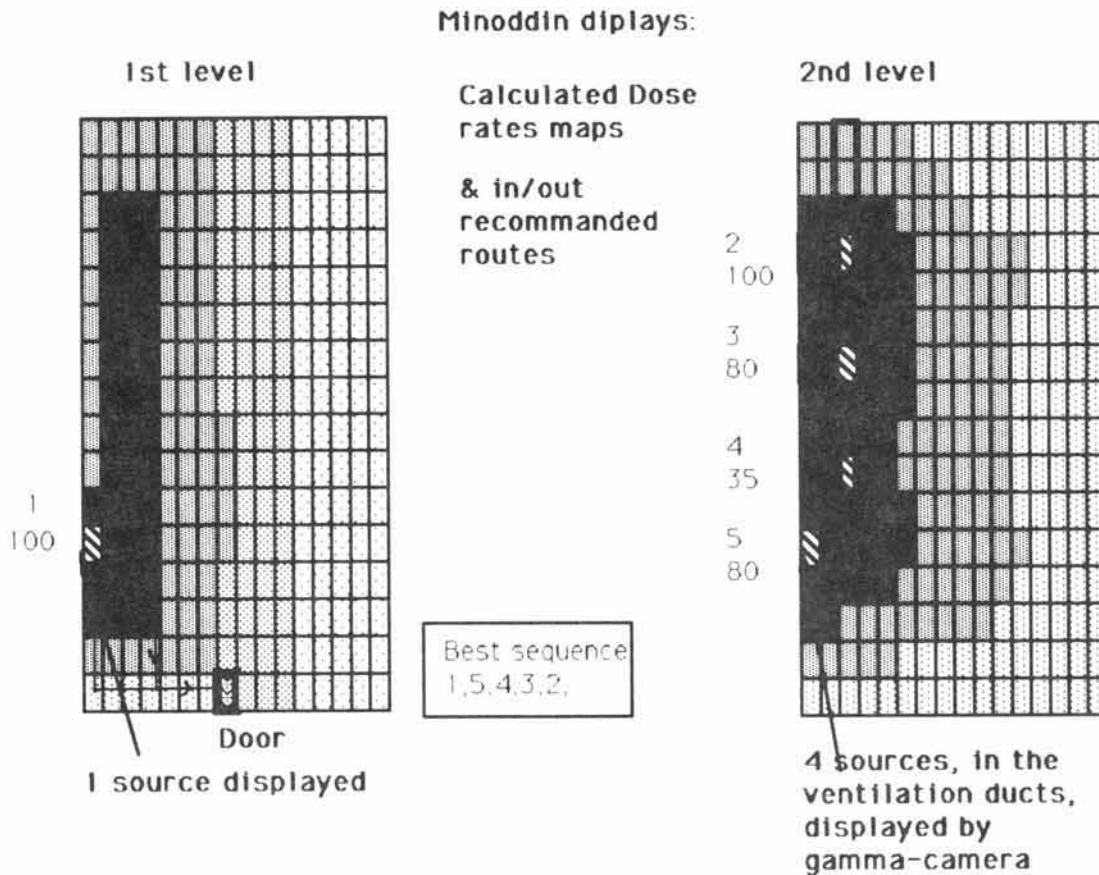

Fig. 3. MINODDIN displays.

contamination immobilized with varnish before cutting them into sections 50 cm long and placing them in waste drums. Minoddin defined a task sequence involving 30% lower occupational doses than the least favorable solution.

#### CONCLUSION

Despite the arsenal of measures taken to reduce occupational doses in nuclear environments, plant operators lacked a predictive simulation tool. The MINODDIN code fills this gap. It is based on solid computing features: a quadtree spatial description, a unit description of individual sources and dose rates, exploration of dismantling sequences using a simple algorithm, artificial intelligence to enhance the realism of the simulation.

The predictive aspect of this code allows it to rationalize human interventions. The program runs on an i486 microcomputer with extended memory.

#### ACKNOWLEDGMENTS

This work was partially funded by the European Communities Research Program on Decommissioning of Nuclear Facilities.

#### REFERENCES

1. T. ZEEVAERT, P. GOUAERTS and P. CROUAIL, *Radiological Optimization in a Reactor Dismantling Programme*, IRPA8 Proceedings, Montreal 1992, pp. 1396-1403.
2. NIS, *Methodology and Data Base for Evaluating Decommissioning Cost and Radiation Exposure*, EC Contract FI 1D 0074 D.
3. M. MINCARINI, *SMANT: Un programma de calcolo per la determinazione della sequenza ottimale di smantellamento del componenti di un impianto nucleare al fine della riduzione delle dosi occupazionali*, Report RT/PAS/88/17 ISSN/0393-6309.